

A

DIMA - TEMPLATE

PORTE DI VETRO
GLASS DOORS
PORTES VITREES
GLASTÜREN
GLAZEN DEUREN
PUERTAS DE VIDRIO

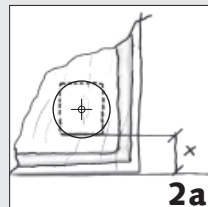
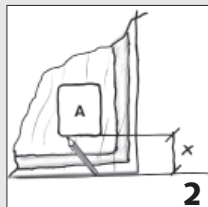
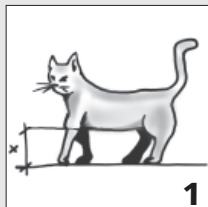

CENTRO PER IL FORO - PORTE DI VETRO
REPERE POUR LE TROU - PORTES VITREES
CENTRE FOR THE HOLE - GLASS DOORS
LOCHMITTE - GLASTÜREN
MIDDELPUNT VAN DE CIRKEL - GLAZEN DEUREN
CENTRO PARA EL AGUJERO - PUERTAS DE VIDRIO

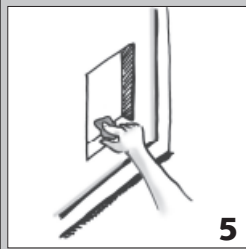
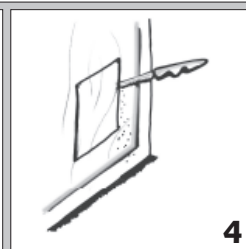
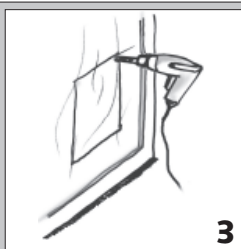
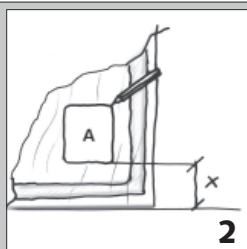
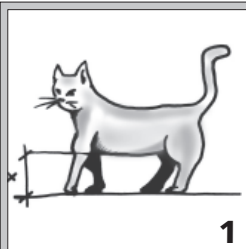

PORTE DI LEGNO, DI METALLO, PARETI E ZANZARIERE
WOODEN, METAL DOORS, WALLS AND SCREENS
PORTES EN BOIS, EN METAL, MURS ET MOUSTIQUAIRES
HOLZ, METALL TÜREN, WÄNDE ODER MÜCKENNETZE
HOUTEN EN METALEN DEUREN, TUSSENWANDEN EN VLIENGGAAS
PUERTAS DE MADERA, DE METAL, PAREDES, MOSQUITERAS

FERITOIA n°1 PER SPESSORI Y=5÷10mm
SLIT n°1 - THICKNESS Y=5÷10mm
FENTE n°1 - EPAISSEUR Y=5÷10mm

SCHLITZ n°1-STÄRKEDURCHMESSER Y=5÷10mm
OPENING WAARIN n°1 - DIKTE Y=5÷10mm
RANURA n°1 - ESPESOR Y=5÷10mm

B

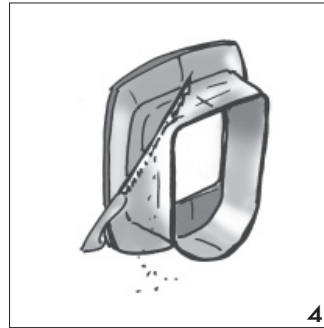
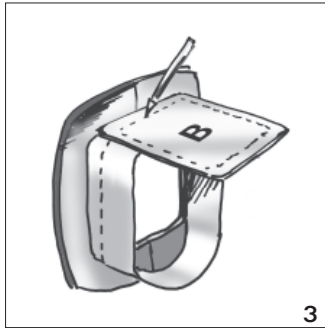
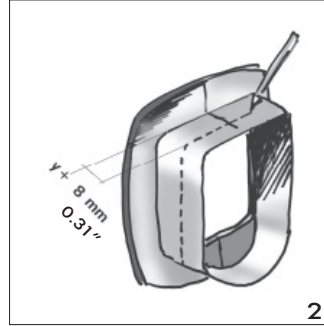
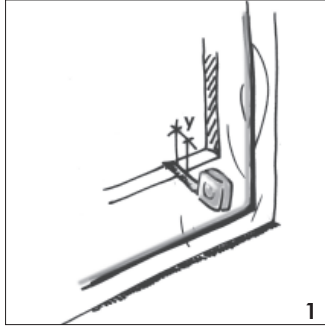

N.B.: Non rifilate il tunnel nella versione piccola selettiva (Swing 7 SET): contiene un meccanismo delicato!

N.B.: Do not cut the tunnel of the small selective-entry Swing 7 SET because it contains delicate mechanism!

N.B.: Ne découpez pas le tunnel dans la version sélective (Swing 7 SET): il contient un mécanisme délicat!

N.B.: Beschneiden Sie den Tunnel der Modellausführung 'select' (Swing 7 SET) auf keinen Fall: dieses Modell verfügt über einen sehr empfindlichen Mechanismus!

N.B.: Opmerking: Snij de tunnel van het luik met keuzevergrendeling (Swing 7 SET) niet af, er zit een delicaat mechanisme in!

N.B.: No recorte el túnel en la versión selectiva (Swing SET): ¡lleva un mecanismo delicado!

FERITOIA n°3 PER SPESSORI Y=25÷30mm
SLIT n°3 - THICKNESS Y=25÷30mm
FENTE n°3 - EPAISSEUR Y=25÷30mm
SCHLITZ n°3 - STÄRKEDURCHMESSER Y=25÷30mm
OPENING WAARIN n°3 - DIKTE Y=25÷30mm
RANURA n°3 - ESPESOR Y=25÷30mm

FERITOIA n°4 PER SPESSORI Y=35÷40mm
SLIT n°4 - THICKNESS Y=35÷40mm
FENTE n°4 - EPAISSEUR Y=35÷40mm
SCHLITZ n°4 - STÄRKEDURCHMESSER Y=35÷40mm
OPENING WAARIN n°4 - DIKTE Y=35÷40mm
RANURA n°4 - ESPESOR Y=35÷40mm

N	Y	Y inch
1	5-10 mm	0.20"-0.39"
2	15-20 mm	0.59"-0.79"
3	25-30 mm	0.98"-1.18"
4	35-40 mm	1.38"-1.57"